

**Model / Modelo / Modèle:**  
**BD-65,**  
**BD-90, BD-90P**  
**BD-120P**  
(115V 60Hz)

## Dehumidifier Owner's Manual

Read and save these instructions

## Manual del propietario del deshumidificador

Lea y guarde estas instrucciones

## Manuel du propriétaire du déshumidificateur

Lisez et gadez ces instructions



**Intertek**

[www.vikingairmovers.com](http://www.vikingairmovers.com) | 1-(855)-855-8868

Index: NA-1-A44  
Edition: 2.1.Final

# Safety Instructions

## **WARNING - READ AND SAVE THESE INSTRUCTIONS BEFORE USING THIS PRODUCT.**

The user of electrical products may create hazards that include, but are not limited to injury, fire, electrical shock. Failure to follow these instructions may damage and/or impair its operation and void the warranty.

- Before operating, remove all packaging material and check for any damage that may have occurred during shipping or any missing items.
- Check household power supply to ensure it matches the appliance's specification.
- **DO NOT** operate the appliance with a damaged cord or plug. Discard or return to an authorized service facility for examination and/or repair.
- Use only with GFCI protected receptacles. Contact a qualified electrician for verification or installation of a GFCI receptacle if necessary.
- **DO NOT** run cord under carpeting. **DO NOT** cover cord with throw rugs, runners, or similar coverings. **DO NOT** route cord under furniture or appliances. Arrange cord away from traffic area and where it will not be tripped over.
- To reduce the risk of fire or electric shock, **DO NOT** use this appliance with any solid state speed control device.
- **DO NOT** touch this appliance or the plug with wet hands or while standing in water.
- **DO NOT** operate the appliance near any pooled water.
- **DO NOT** use the product in areas where gasoline, paint or other flammable goods and objects are used or stored.
- **DO NOT** insert or allow objects to enter any ventilation or exhaust opening as this may damage the appliance and void the warranty.
- **DO NOT** cover the air inlet or outlet on the appliance.
- **DO NOT** direct the air flow at human faces or bodies.
- **DO NOT** allow children to play with this appliance.
- **AUTOMATICALLY OPERATED DEVICE** – To reduce the risk of injury, disconnect from power supply before servicing.
- Remove the power cord from the electrical receptacle by grasping and pulling on the power cord plug-end only, **DO NOT** pull the cord directly.
- **DO NOT** attempt to repair or adjust any electrical or mechanical functions of this appliance, as this may cause danger and void the warranty.
- If the appliance is damaged or it malfunctions, **DO NOT** continue to use it. Unplug the product from the electrical outlet. Refer to troubleshooting guide or contact Viking.
- Store in a dry area, away from exposure to sunlight, extreme temperature and humidity, or other extreme environment, when not in use.
- **DO NOT** stack this appliance to more than three units.
- Always grip the trolley handle and keep the unit up when transporting from room to room. **DO NOT** tilt the product on its side or upside down.
- If the dehumidifier was transported tilted on its side or upside down, you must position it upright and wait at least 4 hours before using it again.
- An electronic instruction manual can be obtained through manufacturer's website [www.vikingairmovers.com](http://www.vikingairmovers.com).

- If the **SUPPLY CORD** is damaged, it **MUST** be replaced by the manufacturer, its service agent or similarly qualified persons in order to avoid a hazard.
- This appliance is **NOT** intended for use by persons (including children) with reduced physical, sensory or mental capabilities, or lack of experience and knowledge, unless they have been given supervision or instruction concerning use of the appliance by a person responsible for their safety. Children should be supervised to ensure that they **DO NOT** play with the appliance.
- The appliance **SHALL** be installed in accordance with national wiring regulations.
- The dimensions of the space necessary for correct installation of the appliance including the minimum permissible distances to adjacent structures.

**WARNING:**

- **DO NOT** use means to accelerate the defrosting process or to clean, other than those recommended by the manufacturer.
- The appliance **SHALL** be stored in a room without continuously operating ignition sources (for example: open flames, an operating gas appliance or an operating electric heater).
- **DO NOT** pierce or burn.
- Be aware that refrigerants **MAY NOT** contain an odour.



**Information for handling, installation, cleaning, servicing and disposal of refrigerant.**

- Warning to keep any required ventilation openings clear of obstruction.
- Notice that servicing shall be performed only as recommended by the manufacturer.
- Warning that the non-FIXED APPLIANCE shall be stored in a room without continuously operating open flames (for example an operating gas appliance) or other POTENTIAL IGNITION SOURCES (for example an operating electric heater, hot surfaces).

(1) **DD.3.3 Qualification of workers**

- (1.1) The manual shall contain specific information about the required qualification of the working personnel for maintenance, service and repair operations. Every working procedure that affects safety means shall only be carried out by competent persons according to Annex HH.
- (1.2) Examples for such working procedures are:
  - (1.2.1) Breaking into the refrigerating circuit
  - (1.2.2) Opening of sealed components;
  - (1.2.3) Opening of ventilated enclosures.

(2) **DD.4 Information on servicing**

(2.1) **DD.4.1 General**

- (2.1.1) The manual shall contain specific information for service personnel according to DD.4.2 to DD.4.10.

(2.2) **DD.4.2 Checks to the area**

- (2.2.1) Prior to beginning work on systems containing **FLAMMABLE REFRIGERANTS**, safety checks are necessary to ensure that the risk of

ignition is minimized. For repair to the REFRIGERATING SYSTEM.

(2.3) **DD.4.3 Work procedure**

(2.3.1) Work shall be undertaken under a controlled procedure so as to minimize the risk of a flammable gas or vapor being present while the work is being performed.

(2.4) **DD.4.4 General work area**

(2.4.1) All maintenance staff and others working in the local area shall be instructed on the nature of work being carried out. Work in confined spaces shall be avoided.

(2.5) **DD.4.5 Checking for presence of refrigerant**

(2.5.1) The area shall be checked with an appropriate refrigerant detector prior to and during work, to ensure the technician is aware of potentially toxic or flammable atmospheres. Ensure that the leak detection equipment being used is suitable for use with all applicable refrigerants, i. e. non-sparking, adequately sealed or intrinsically safe.

(2.6) **DD.4.6 Presence of fire extinguisher**

(2.6.1) If any hot work is to be conducted on the refrigerating equipment or any associated parts, appropriate fire extinguishing equipment shall be available to hand. Have a dry powder or CO2 fire extinguisher adjacent to the charging area.

(2.7) **DD.4.7 No ignition sources**

(2.7.1) No person carrying out work in relation to a **REFRIGERATING SYSTEM** which involves exposing any pipe work shall use any sources of ignition in such a manner that it may lead to the risk of fire or explosion. All possible ignition sources, including cigarette smoking, should be kept sufficiently far away from the site of installation, repairing, removing and disposal, during which refrigerant can possibly be released to the surrounding space. Prior to work taking place, the area around the equipment is to be surveyed to make sure that there are no flammable hazards or ignition risks. "No Smoking" signs shall be displayed.

(2.8) **DD.4.8 Ventilated area**

(2.8.1) Ensure that the area is in the open or that it is adequately ventilated before breaking into the system or conducting any hot work. A degree of ventilation shall continue during the period that the work is carried out. The ventilation should safely disperse any released refrigerant and preferably expel it externally into the atmosphere.

(2.9) **DD.4.9 Checks to the refrigerating equipment**

(2.9.1) Where electrical components are being changed, they shall be fit for the purpose and to the correct specification. At all times the manufacturer's maintenance and service guidelines shall be followed. If in doubt, consult the manufacturer's technical department for assistance.

(2.9.2) The following checks shall be applied to installations using **FLAMMABLE REFRIGERANTS:**

– the actual **REFRIGERANT CHARGE** is in accordance with the room

- size within which the refrigerant containing parts are installed;
  - the ventilation machinery and outlets are operating adequately and are not obstructed;
  - if an indirect refrigerating circuit is being used, the secondary circuit shall be checked for the presence of refrigerant;
  - marking to the equipment continues to be visible and legible.
- Markings and signs that are illegible shall be corrected;
- refrigerating pipe or components are installed in a position where

they are unlikely to be exposed to any substance which may corrode refrigerant containing components, unless the components are constructed of materials which are inherently resistant to being corroded or are suitably protected against being so corroded.

**(2.10) DD.4.10 Checks to electrical devices**

(2.10.1) Repair and maintenance to electrical components shall include initial safety checks and component inspection procedures. If a fault exists that could compromise safety, then no electrical supply shall be connected to the circuit until it is satisfactorily dealt with. If the fault cannot be corrected immediately but it is necessary to continue operation, an adequate temporary solution shall be used. This shall be reported to the owner of the equipment so all parties are advised.

**(2.10.2) Initial safety checks shall include:**

- that capacitors are discharged: this shall be done in a safe manner to avoid possibility of sparking;
- that no live electrical components and wiring are exposed while charging, recovering or purging the system;
- that there is continuity of earth bonding.

**(3) DD.5 Repairs to sealed components**

(3.1) DD.5.1 During repairs to sealed components, all electrical supplies shall be disconnected from the equipment being worked upon prior to any removal of sealed covers, etc. If it is absolutely necessary to have an electrical supply to equipment during servicing, then a permanently operating form of leak detection shall be located at the most critical point to warn of a potentially hazardous situation.

(3.2) DD.5.2 Particular attention shall be paid to the following to ensure that by working on electrical components, the casing is not altered in such a way that the level of protection is affected. This shall include damage to cables, excessive number of connections, terminals not made to original specification, damage to seals, incorrect fitting of glands, etc.

(3.2.1) Ensure that the apparatus is mounted securely.

(3.2.2) Ensure that seals or sealing materials have not degraded to the point that they no longer serve the purpose of preventing the ingress of flammable atmospheres. Replacement parts shall be in accordance with the manufacturer's specifications.

(4) **DD.6 Repair to intrinsically safe components**

- (4.1) Do not apply any permanent inductive or capacitance loads to the circuit without ensuring that this will not exceed the permissible voltage and current permitted for the equipment in use.
- (4.2) Intrinsically safe components are the only types that can be worked on while live in the presence of a flammable atmosphere. The test apparatus shall be at the correct rating.
- (4.3) Replace components only with parts specified by the manufacturer. Other parts may result in the ignition of refrigerant in the atmosphere from a leak.
- (4.4) NOTE The use of silicon sealant can inhibit the effectiveness of some types of leak detection equipment. Intrinsically safe components do not have to be isolated prior to working on them.

(5) **DD.7 Cabling**

- (5.1) Check that cabling will not be subject to wear, corrosion, excessive pressure, vibration, sharp edges or any other adverse environmental effects. The check shall also take into account the effects of aging or continual vibration from sources such as compressors or fans.

(6) **DD.8 Detection of flammable refrigerants**

- (6.1) Under no circumstances shall potential sources of ignition be used in the searching for or detection of refrigerant leaks. A halide torch (or any other detector using a naked flame) shall not be used.
- (6.2) The following leak detection methods are deemed acceptable for all refrigerant systems.
- (6.3) Electronic leak detectors may be used to detect refrigerant leaks but, in the case of **FLAMMABLE REFRIGERANTS**, the sensitivity may not be adequate, or may need re-calibration. (Detection equipment shall be calibrated in a refrigerant-free area.) Ensure that the detector is not a potential source of ignition and is suitable for the refrigerant used. Leak detection equipment shall be set at a percentage of the LFL of the refrigerant and shall be calibrated to the refrigerant employed, and the appropriate percentage of gas (25 % maximum) is confirmed.
- (6.4) Leak detection fluids are also suitable for use with most refrigerants but the use of detergents containing chlorine shall be avoided as the chlorine may react with the refrigerant and corrode the copper pipe-work
- (6.5) **NOTE Examples of leak detection fluids are**
  - (6.5.1) bubble method,
  - (6.5.2) fluorescent method agents
- (6.6) If a leak is suspected, all naked flames shall be removed/extinguished.
- (6.7) If a leakage of refrigerant is found which requires brazing, all of the refrigerant shall be recovered from the system, or isolated (by means of shut off valves) in a part of the system remote from the leak.

(7) **DD.9 Removal and evacuation**

- (7.1) When breaking into the refrigerant circuit to make repairs – or for any other purpose – conventional procedures shall be used. However, for flammable refrigerants it is important that best practice be followed, since flammability is a consideration. The following procedure shall be adhered to:
- a) safely remove refrigerant following local and national regulations;
  - b) purge the circuit with inert gas;
  - c) evacuate (optional for A2L);
  - d) purge with inert gas (optional for A2L);
  - e) open the circuit by cutting or brazing.
- (7.2) The refrigerant charge shall be recovered into the correct recovery cylinders if venting is not allowed by local and national codes. For appliances containing flammable refrigerants, the system shall be purged with oxygen-free nitrogen to render the appliance safe for flammable refrigerants. This process might need to be repeated several times.
- (7.3) Compressed air or oxygen shall not be used for purging refrigerant systems.
- (7.4) For appliances containing flammable refrigerants, refrigerants purging shall be achieved by breaking the vacuum in the system with oxygen-free nitrogen and continuing to fill until the working pressure is achieved, then venting to atmosphere, and finally pulling down to a vacuum (optional for A2L). This process shall be repeated until no refrigerant is within the system (optional for A2L). When the final oxygen-free nitrogen charge is used, the system shall be vented down to atmospheric pressure to enable work to take place.
- (7.5) Ensure that the outlet for the vacuum pump is not close to any potential ignition sources and that ventilation is available.

(8) **DD.10 Charging procedures**

- (8.1) In addition to conventional charging procedures, the following requirements shall be followed.
- (8.2) Ensure that contamination of different refrigerants does not occur when using charging equipment.
- (8.3) Hoses or lines shall be as short as possible to minimise the amount of refrigerant contained in them.
- (8.4) Cylinders shall be kept in an appropriate position according to the instructions.
- (8.5) Ensure that the **REFRIGERATING SYSTEM** is earthed prior to charging the system with refrigerant.
- (8.6) Label the system when charging is complete (if not already).
- (8.7) Extreme care shall be taken not to overfill the **REFRIGERATING SYSTEM**.
- (8.8) Prior to recharging the system, it shall be pressure-tested with the appropriate purging gas. The system shall be leak-tested on completion of charging but prior to commissioning. A follow up leak test shall be carried out prior to leaving the site.

(9) **DD.11 Decommissioning**

- (9.1) Before carrying out this procedure, it is essential that the technician is completely

familiar with the equipment and all its detail. It is recommended good practice that all refrigerants are recovered safely.

- (9.2) Prior to the task being carried out, an oil and refrigerant sample shall be taken in case analysis is required prior to re-use of recovered refrigerant. It is essential that electrical power is available before the task is commenced.
- a) Become familiar with the equipment and its operation.
  - b) Isolate system electrically.
  - c) Before attempting the procedure, ensure that:
    - mechanical handling equipment is available, if required, for handling refrigerant cylinders;
    - all personal protective equipment is available and being used correctly;
    - the recovery process is supervised at all times by a competent person;
    - recovery equipment and cylinders conform to the appropriate standards.
  - d) Pump down refrigerant system, if possible.
  - e) If a vacuum is not possible, make a manifold so that refrigerant can be removed from various parts of the system.
  - f) Make sure that cylinder is situated on the scales before recovery takes place.
  - g) Start the recovery machine and operate in accordance with instructions.
  - h) Do not overfill cylinders (no more than 80 % volume liquid charge).
  - i) Do not exceed the maximum working pressure of the cylinder, even temporarily.
  - j) When the cylinders have been filled correctly and the process completed, make sure that the cylinders and the equipment are removed from site promptly and all isolation valves on the equipment are closed off.
  - k) Recovered refrigerant shall not be charged into another **REFRIGERATING SYSTEM** unless it has been cleaned and checked.

#### (10) **DD.12 Labeling**

- (10.1) Equipment shall be labeled stating that it has been decommissioned and emptied of refrigerant. The label shall be dated and signed. For appliances containing **FLAMMABLE REFRIGERANTS**, ensure that there are labels on the equipment stating the equipment contains **FLAMMABLE REFRIGERANT**.

#### (11) **DD.13 Recovery**

- (11.1) When removing refrigerant from a system, either for servicing or decommissioning, it is recommended good practice that all refrigerants are removed safely.
- (11.2) When transferring refrigerant into cylinders, ensure that only appropriate refrigerant recovery cylinders are employed. Ensure that the correct number of cylinders for holding the total system charge is available. All cylinders to be used are designated for the recovered refrigerant and labeled for that refrigerant (i. e. special cylinders for the recovery of refrigerant). Cylinders shall be complete with pressure-relief valve and associated shut-off valves in good working order. Empty recovery cylinders are evacuated and, if possible, cooled before recovery occurs.



- (11.3) The recovery equipment shall be in good working order with a set of instructions concerning the equipment that is at hand and shall be suitable for the recovery of all appropriate refrigerants including, when applicable, **FLAMMABLE REFRIGERANTS**. In addition, a set of calibrated weighing scales shall be available and in good working order. Hoses shall be complete with leak-free disconnect couplings and in good condition. Before using the recovery machine, check that it is in satisfactory working order, has been properly maintained and that any associated electrical components are sealed to prevent ignition in the event of a refrigerant release. Consult manufacturer if in doubt.
- (11.4) The recovered refrigerant shall be returned to the refrigerant supplier in the correct recovery cylinder, and the relevant waste transfer note arranged. Do not mix refrigerants in recovery units and especially not in cylinders.
- (11.5) If compressors or compressor oils are to be removed, ensure that they have been evacuated to an acceptable level to make certain that **FLAMMABLE REFRIGERANT** does not remain within the lubricant. The evacuation process shall be carried out prior to returning the compressor to the suppliers. Only electric heating to the compressor body shall be employed to accelerate this process. When oil is drained from a system, it shall be carried out safely.
- (11.6) When installing this equipment, the minimum allowable distance from adjacent structures should be guaranteed to be 10cm.

### **Information for qualification of workers**

- All operators or refrigeration system maintenance personnel shall have a valid certificate issued by an industry-recognized evaluation body to certify that they are qualified for the safe disposal of refrigerant agents as recognized by the industry;
- Maintain and repair the equipment only in accordance with the method recommended by the equipment manufacturer. If other professionals are required to assist in the maintenance and repair of equipment, do so under the supervision of personnel qualified to use combustible refrigerants.

Class	Name	Classification of instructions	Personnel Qualification Requirements
A	Professional Maintenance Personnel	Personnel, such as installers and maintenance supervisors, who are required to install, repair, and weld the refrigeration system for flammable refrigerant products	Hold A class A certificate issued by the competent authority, available online.
B	Regular contacts personnel	<ol style="list-style-type: none"> <li>1. Personnel who do not need to open the refrigeration system of combustible refrigerant products, such as relevant personnel of transportation enterprises and general maintenance personnel of product after-sales department, etc</li> <li>2. Installation and maintenance personnel of conventional refrigerant products</li> </ol>	Hold a Class B certificate issued by the competent authority, available online.
C (The enterprise internal)	Develop, design and test personnel	Combustible refrigerant system design personnel, supervision personnel	<ol style="list-style-type: none"> <li>1. Master the skills and knowledge of basic safety welding and safety protection level of combustible refrigerant:</li> <li>2. Familiar with product development process and capable of design:</li> <li>3. Qualification certification/recognition shall be conducted by the institution where you work</li> </ol>

- (1) Personnel with class A certificate can carry out the operation of class B personnel;
- (2) Class A and Class B personnel shall be trained and certified by the industry management institution designated by the state;
- (3) C type personnel should participate in the company's internal organization of professional training, obtain internal issued certification or accreditation qualifications.

Tooling Names	Use Requirement
Small Vacuum Pump	Explosion-proof vacuum pump: ensure a certain accuracy, vacuum degree should be less than 10Pa.
Filling Equipment	Special explosion-proof charging equipment: with certain accuracy, the charging amount deviation is less than 5g.
Leak Detector	Regular calibration: annual leakage rate is not higher than 10g.
Concentration Detector	<p>A) The maintenance site shall be equipped with A fixed combustible refrigerant concentration detector, which shall be connected to the safety protection alarm system: its error must be guaranteed not to be higher than 5%.</p> <p>B) The installation site shall be equipped with portable combustible refrigerant concentration detector, which can realize two-level acoustic-optic alarm: its error must be guaranteed not to be higher than 10%.</p> <p>C) Regular calibration.</p> <p>D) Function check and confirmation shall be carried out before use.</p>
Pressure Gauge	<p>A) The pressure gauge shall be calibrated regularly</p> <p>B) R290 and R161 refrigerant can use the pressure gauge of R22, R32 refrigerant can use the pressure gauge of R410A.</p>
Fire Extinguisher	<p>Carry a fire extinguisher during installation and maintenance.</p> <p>There should be at least two kinds of dry powder, carbon dioxide and foam extinguishers in the maintenance site, and they should be placed in the prescribed position with eye-catching signs and accessible places.</p>

- (1) The installation site should be in a well-ventilated condition.
- (2) The sites for installing and maintaining an air conditioner using Refrigerant R32 should be free from open fire or welding smoking, drying oven or any other heat source higher than 548 °C which easily produces open fire.
- (3) When installing an air conditioner, it is necessary to take appropriate anti-static measures such as wear anti-static clothing and or gloves.
- (4) It is necessary to choose the site convenient for installation or maintenance wherein the air inlets and outlets of the indoor and outdoor units should be not surrounded by obstacles or close to any heat source or combustible and/or explosive environment.
- (5) If the indoor unit suffers refrigerant leak during the installation, all the personnel should go out till the refrigerant leaks completely for 15 minutes. If the product is damaged, it is a must to carry such damaged product back to the maintenance station and it is prohibited to weld the refrigerant pipe or conduct other operations on the user's site.

- (6) It is necessary to choose the place where the inlet and outlet air of the indoor unit is even.
- (7) It is necessary to avoid the places where there are other electrical products, power switch plugs and sockets, kitchen cabinet, bed, sofa and other valuables right under the lines on two sides of the indoor unit, and also prevent mechanical damage from occurring.

### **Handling of Refrigerants**

The handling, installation, storage, servicing and disposal must comply with the provisions of gas-related national laws and regulations, and also national wiring regulation.

It is necessary to clear away the refrigerant in the system when maintaining or scrapping an appliance.

### **Ventilated Area (Open Doors and Windows)**

Ensure that the working area is open or well ventilated before turning on the system or performing hot work. Ventilation should be maintained during operation. Ventilation quickly displaces safely diluted leaked refrigerant into the atmosphere.

Flammable refrigerant R32 is used within appliance. Please follow the instructions carefully to handle, install, clean, and service the appliance to avoid damage or hazard. Do not dispose of appliance in regular trash. Contact qualified agency for proper disposal.

Servicing shall be performed only as recommended by the manufacturer.



# Whole House Dehumidifier Introduction

- Viking whole house dehumidifiers are designed to effectively remove excess moisture from the air and maintain proper humidity levels with their high performance and efficiency.
- The standard environmentally friendly refrigerant and auto defrost function make it operate efficiently in temperatures as low as 33 ° F. You can choose a gravity drain or pump drain according to the working environment. It works well to keep your place mold and moisture-free throughout the seasons.
- Compact size and installation flexibility make these dehumidifiers ideal for almost any application. Perfect for any household, crawl space, basement, storage area, garage, office, or commercial place.

## Items Included

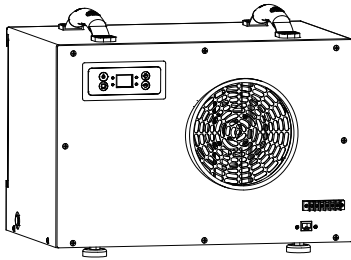

Dehumidifier x 1

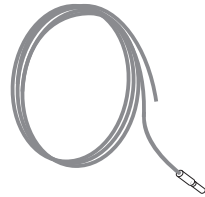

Drain Hose x 1



Owner's Manual x 1

# Parts Description

For Model BD-65

## FRONT

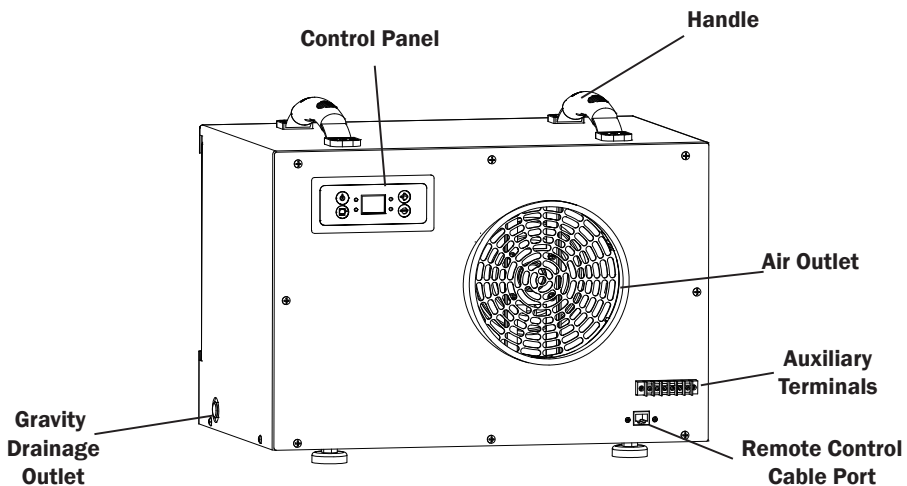

## REAR

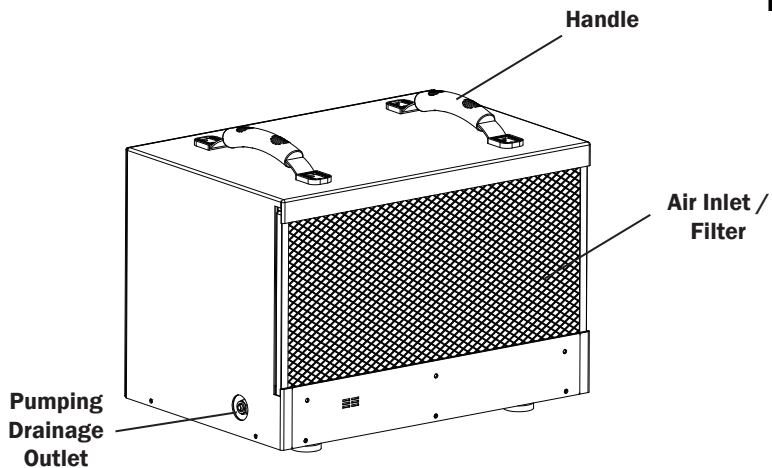

**FRONT**

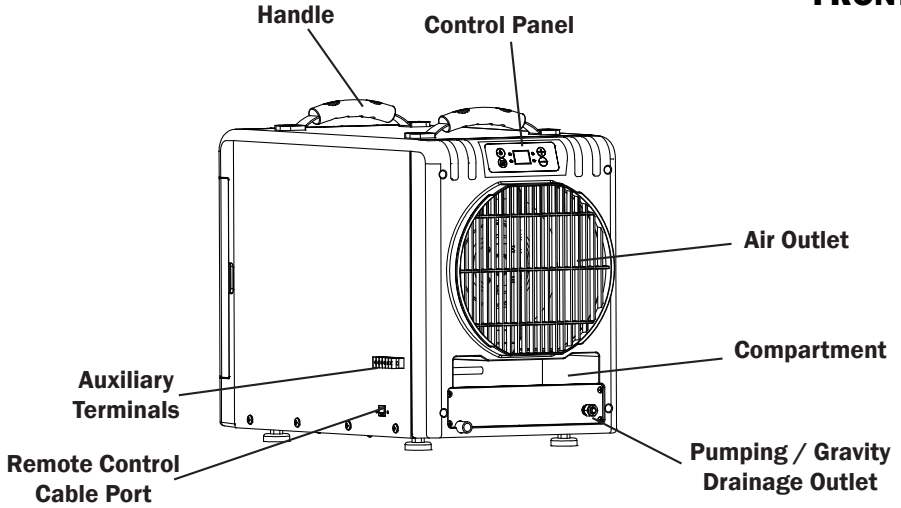

**REAR**

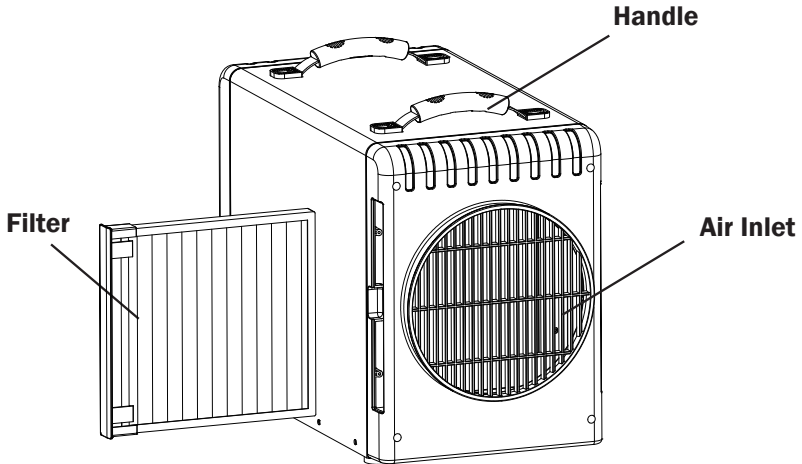



# Installation and Operation Guide

## Selecting a Location (Important)

- **Positioning:** Before using the dehumidifier, place the unit **UPRIGHT** for at least 1 hour before use to allow the refrigerant to stabilize. If the unit was tilted on its side or upside-down during transportation, set the unit **UPRIGHT** for at least 4 hours before use. The dehumidifier must be positioned **UPRIGHT** on a level surface during use.
- **Enclosed Area:** For optimal efficiency, the dehumidifier must be operated in an enclosed area. Keep all doors, windows and other outside entrances to the room closed. Turn off the air conditioning.
- **Air Circulation:** It's suggested to have a constant efficient air circulation inside the area that you are going to work in, for example, setting up a circulation with Air Mover combinations.
- **Power Cord and Drain Hose:** The power cord has a length of 10 feet (3.0 m) and the drain hose has a length of 40 feet (12.0 m). Select a location where the power cord can reach the power source and the drain hose can reach the area you want. Please do not lift the drainage hose higher than 16 feet (5.0 m) above the machine.
- **Inlet and Outlet Orientation:** Also pay attention to the orientation of the air inlet and air outlet. Make sure the airflow won't influence any object nearby the dehumidifier.
- **IMPORTANT:** The effectiveness of the dehumidifier can be influenced by different factors. You should keep any new moisture-laden air away from the working area and allow sufficient enclosed air circulation in the room. You may also find that installing multiple dehumidifiers may be required for larger enclosed areas.

### Gravity Drainage

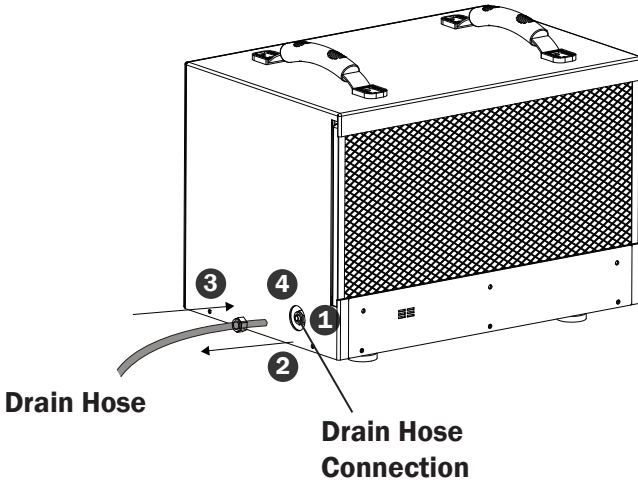

- (1) Unscrew the nut at the Drain Hose Connection.
- (2) The Drain Hose passes through the nut.
- (3) Insert the Drain Hose into the connection.
- (4) Screw the nut back to the Drain Hose Connection.

### For model BD-90

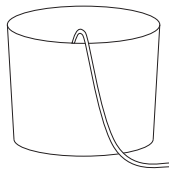
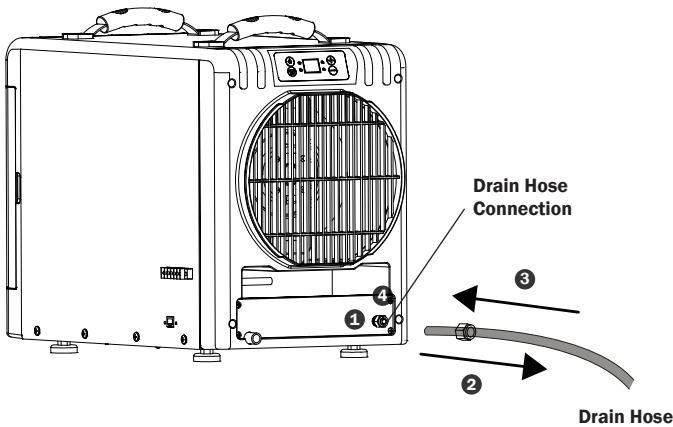

- Please have a separate container to collect the water coming from the other end of the drain hose.

## Extension Setup (Optional)

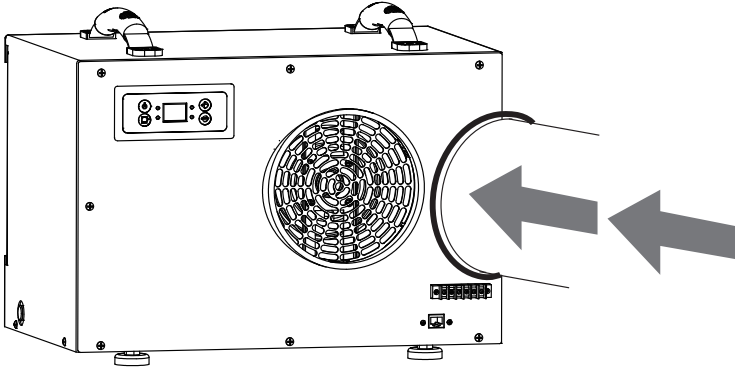

### Intake Ducting\*

Attach the ducting hose to the intake adapter.

\* Ducting Diameter: For BD-65: over 6.5 inch / 16.5 cm; For BD-90 series: over 10 inch / 25.0 cm;

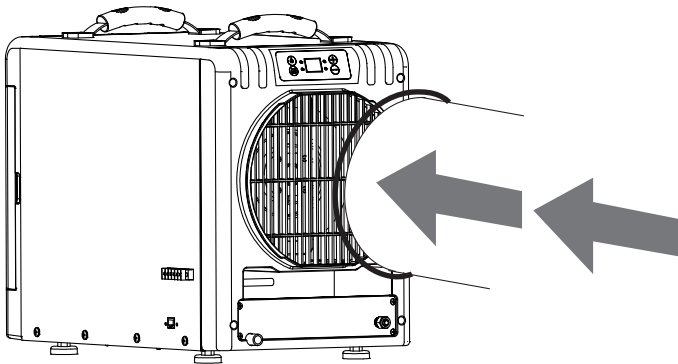

### Exhaust Ducting\* (Lay Flat)

Attach the ducting hose to the exhaust adapter.

\* For BD-90 Series and BD-120 Series only.  
Ducting Diameter: For BD-90 series: over 10 inch / 25.0 cm;

## Control Panel

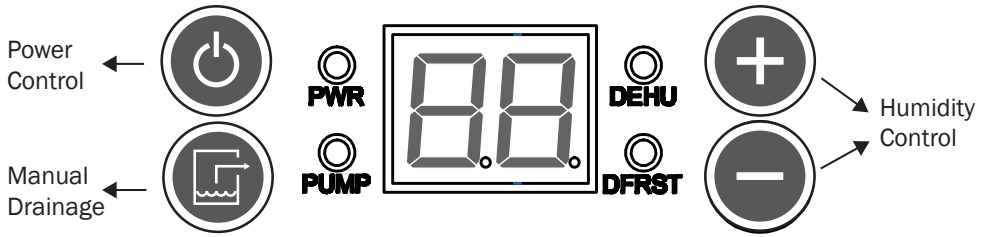

### Buttons



#### Power Control

Press to switch the dehumidifier ON or OFF.



#### Manual Drainage

Press to drain manually. Manual drain will last for 45 seconds.



#### Humidity Control

Tap "+" / "-" to increase/decrease the desired humidity level by 1% increments. Touch and hold to increase/decrease the setting humidity level by 5% per second. The adjustable range is 36% to 90%.

### Information

#### Relative Humidity Display

This will show the relative humidity level of the setting or environment. As default, it displays the environment humidity. When adjusting humidity, it will display the setting humidity and blink. After 60 seconds from the last adjustment, it will display the environment humidity again.

### Indicators

#### Power Light

When this light is red indicates the machine is connected to power source and it is now turned on.

#### Drainage Indicator Light

When this light is green indicates the pump is now turned on.

#### Dehumidification Light

When this light is red, it indicates the machine is now preparing for dehumidification (This process takes about 3 minutes). When this light is green, it indicates the machine is now dehumidifying.

### Defrosting Light

When the compressor stops working to defrost, the defrosting light turns red, indicating that the machine is in automatic defrost mode. The defrosting light turns green, indicating that the machine will enter into constant dehumidification mode.

### Error Codes

These are error codes. Please refer to Troubleshooting Guide for more information.

### Constant Dehumidification

At the humidity level setting of 36%, if humidity control button “-” is pressed, will blink on the humidity display. The machine will enter into constant dehumidification mode and won't stop dehumidification as environment humidity changes.

## Start Your Job

### Turn on the dehumidifier

Press the Power Control button to switch on the machine. You may see the dehumidification light is flashing. Please wait for 3 minutes (180 seconds) until the machine completes the startup.

### Set the desired humidity level

- Tap the humidity control button to adjust the setting humidity level. The default humidity setting is 36%. The adjust range is from 36% to 90% (See *Page 8: Humidity Control*). The machine will try to match the setting humidity level and maintain it.
- If you want the machine to work constantly, please adjust the humidity level down to 36%, and then press “-” (See *Page 9: Constant Dehumidification*). Tap “+” to exit constant dehumidification mode.
- If the dehumidifier loses power accidentally, when turned on again, the dehumidifier will work on the last known configuration.

### Dehumidification

- When the machine is dehumidifying, the dehumidification light is green.
- You may see the dehumidification light is flashing. That means the dehumidification temporarily pauses or the environment humidity has reached the setting level. Please wait until the machine completes the startup or until the humidity level rises up again.
- The dehumidifier will control the fan speed according to the environment temperature and humidity.

### Defrosting

- When the evaporator coil or the environment temperature is too low, frost may appear on the evaporator. This will cause a lower effectiveness of the dehumidification. The

## Start Your Job (Continued)

machine will start defrosting until the temperature goes back to normal.

- When the machine is defrosting, the dehumidification pauses. The dehumidification light goes off, and the defrosting light will be red.
- Do not turn off the machine during defrosting process.

## Drainage (Important)

- Press the Manual Drainage button to process drainage manually. It will last for 70 seconds and won't stop dehumidification or defrosting process.
- If the water tank is full or not positioned horizontally, the drainage indicator light will go on. Any dehumidification or defrosting process will pause and the machine will automatically process drainage for 70 seconds. Afterwards, if the water tank is still detected full, an error code will be displayed (*See Page 9: Error Codes or Page 14: Troubleshooting Guide*).
- When turned off, the machine will automatically process drainage for 70 seconds. Please wait until this process completes.
- Please do not lift the drainage hose higher than 16 feet (5 m) above the machine.

## Turn off the dehumidifier

Press the Power Control button to switch off the machine. When turned off, the machine will automatically process drainage for 60 seconds. Please wait until this process completes.

## Transportation

### Before transportation, you should always:

- Process a drainage manually. Otherwise the water may spill and enter in core parts of the machine during transportation. This may also void the warranty.
- Disconnect the machine from the power source.
- Remove all the extension setup and uninstall the power cord and drain hose.

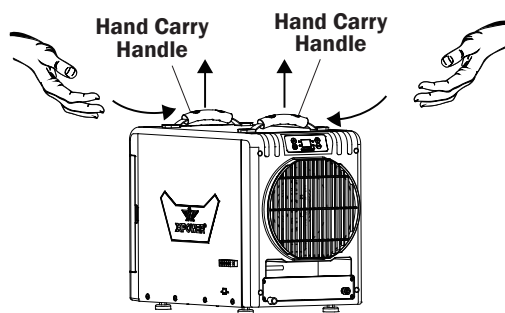

### Lift with Hand Carry Handles

- Lift the dehumidifier with the two hand carry handles on the top.
- Be aware of the weight of the machine.

# User Maintenance Instructions

Frequent maintenance is recommended on this appliance. Failure to follow the maintenance instructions may cause failure of the appliance and void the warranty.

## **Before maintenance or storage, you should always:**

- Process a drainage manually.
- Disconnect the machine from the power source.
- Remove all the extension setup.

## **Clean the surface**

- Use a damp cloth to wipe the surface of the housing. Do not clean the unit with water directly.
- Do not clean the fins of the evaporator and condenser by yourself.

## **Store the machine**

- Store the appliance in a dry and cool indoor place, away from direct sunlight as well as chemicals and out of reach of children.
- **IMPORTANT:** make sure the machine is levelly positioned.
- If you want to stack this appliance, stack them on their tops with the same orientation.
- Do not stack more than three units of this appliance.

# Troubleshooting Guide

PROBLEM	POSSIBLE CAUSE	SOLUTION
Dehumidifier does not start	No electricity.	Check for power supply.
	The power cord is not properly plugged in.	Remove and reconnect the power cord.
Dehumidifier runs but humidity level does not decrease	The dehumidification system is within startup process.	Wait for 3 minutes (180 seconds) until the dehumidification light stops blinking.
	The humidity level setting is too high.	Decrease the humidity level setting.
	The working area is not enclosed.	Make sure the area is tightly sealed.
	There are other sources of humidity in the room.	Remove these sources or wait until they completely volatilize.
	The humidity level has reached the setting level.	Decrease the humidity level setting, set to constant dehumidification mode, wait until the humidity level rises up again.
Dehumidifier runs but humidity level does not decrease	The machine was tilted and wasn't positioned upright for enough time before use.	Position the machine upright on a level surface and wait for at least 4 hours before next use.
	The air filter or air inlet/outlet is blocked.	Remove blockage.
	The environment temperature is too low/high or the humidity level is too low.	The dehumidifier is designed to work in an environment with a temperature of 33 °F to 105 °F (0.6 °C to 40.6 °C) and relative humidity level of 20% and higher. Make sure the room temperature/humidity does not exceed this range.



# Troubleshooting Guide (Continued)

PROBLEM	POSSIBLE CAUSE	SOLUTION
Water on the floor	The drain hose is loose.	Tighten the connection of the drain hose.
Sudden noise	The machine starts drainage process.	The water pump can create sounds during operation. This is a normal sound.

## Error Codes

ERROR CODES	POSSIBLE CAUSE	SOLUTION
E2	Failure of the temperature sensor.	The dehumidification can function but you won't be able to see the temperature/humidity on the screen. Contact Viking for more assistance.
E3	Failure of the humidity sensor.	
E4	Failure of the water pump	Contact Viking for more assistance.
	The machine is not positioned levelly.	Position the machine on a level surface.
	The drain hose is blocked.	Remove blockage.
E5	Failure of the defrost sensor.	The dehumidification can function but will defrost for 5 minutes every half an hour. Contact Viking for more assistance.

If troubleshooting does not resolve your problem, please contact Viking or other parties authorized by Viking for further instructions.

# Technical Specification

MODEL NUMBER	BD-65	BD-90	BD-90P	BD-120P
Voltage / Frequency	115 V~, 60 Hz			
Amperage	4.2 A	5.8 A		7.8 A
Operation Temperature/ Relative Humidity Requirement	33 °F - 105 °F (0.6 °C to 40.6 °C) / 36% RH or higher			
Rated Airflow	180 CFM			N/A
Speed Control	Automatic			
Water Removal Efficiency 80 °F (26.7 °C) / 60% RH	60 Pints (26 L)/day	85 Pints (40 L)/day		115 Pints (54 L)/day
Water Removal Efficiency 65 °F (18.3 °C) / 60% RH	36.8 Pints (17.4 L) / day	N / A		N / A
Water Removal Efficiency 73 °F (22.8 °C) / 60% RH	N / A	69.4 Pints (32.8 L) / day		N / A
Energy Factor	1.83 L/kWh	2.28 L/kWh		N / A
Refrigerant	R32 / 300 g	R32 / 440 g		R32 / 520 g
Compartment Feature	No	Yes		
Filter Type	Polyester Filter	Stainless Steel Filter		
Cord Length	18.4 ft. / 5.6 m	18.0 ft. / 5.5 m		
Drain Hose Length	20.0 ft. / 6.1 m			
Unit Dimension (L) x (W) x (H)	17.8 x 13.1 x 14.0 in. / 45.3 x 33.2 x 35.6 cm	23.6 x 12.4 x 18.0 in. / 60.0 x 31.5 x 45.6 cm		23.6 x 15.2 x 18.4 in. / 60.0 x 38.5 x 46.8 cm
Unit Weight	55.1 lbs. / 25.0 kg	66.1 lbs. / 30.0 kg	69.2 lbs. / 31.4 kg	82.2 lbs. / 37.3 kg
Safety Certification	ETL / C-ETL			N / A

If your product(s) is not listed above, please visit [www.vikingairmovers.com](http://www.vikingairmovers.com) for more information.

# Viking Limited Warranty (USA)

## 1 YEAR LIMITED WARRANTY

Viking-branded products purchased in the U.S. from authorized distributors include a 1-year limited warranty. Contact Viking to confirm warranty information about your product(s).

This limited warranty covers defects in materials and workmanship in your Viking-branded products, purchased in the **U.S. ONLY**. Local warranty policy (if any) in your country will cover products purchased outside the U.S.

### **IMPORTANT:**

- (1) Please finish the online warranty registration before usage. Visit [www.vikingairmovers.com/service-support/warranty-registration](http://www.vikingairmovers.com/service-support/warranty-registration).
- (2) This Limited Warranty applies with its own timeliness. Contact Viking or visit [www.vikingairmovers.com](http://www.vikingairmovers.com) for more information.

### **Items mentioned but not limited to below are not covered by warranty:**

- (1) Power cord, filters or any other components considered as a “consumable parts” by Viking.
- (2) Normal wear and tear.
- (3) Problems that result, directly or indirectly, at Viking’s sole discretion, from:
  - (3.1) External causes such as accident, abuse, misuse or problems with electrical power supply.
  - (3.2) Disassembling, servicing or modification not authorized by Viking.
  - (3.3) Usage that is not accordant with product instructions stated in Owner’s Manual.
  - (3.4) Failure to follow the product instructions or lack of necessary maintenance stated in Owner’s Manual.

### **Before contacting Viking, please try one or more of the following:**

- (1) Consult this Owner’s Manual and follow the instructions of troubleshooting guide.
- (2) Access [www.vikingairmovers.com](http://www.vikingairmovers.com) for more advice and information that could be helpful to address your problems.

### **If you need additional assistance from Viking, please:**

- (1) Email [info@xpower.com](mailto:info@xpower.com) or [support@xpower.com](mailto:support@xpower.com).
- (2) Call Viking U.S. Customer Service Department at **855-855-8868** or other numbers provided on [www.vikingairmovers.com](http://www.vikingairmovers.com).
- (3) Visit Viking U.S. Head Office at **668 S. 6th Ave., City of Industry, CA 91746** or the most current address provided on [www.vikingairmovers.com](http://www.vikingairmovers.com).

Please also have your original proof of purchase and the serial number(s) of your product(s) ready when you contact Viking.



**VIKING Equipment Co., Inc.**

668 S. 6th Ave.,  
City of Industry, CA 91746 USA  
[www.vikingairmovers.com](http://www.vikingairmovers.com) | 1-(855)-855-8868

Read and save these instructions  
Lea y guarde estas instrucciones  
Lisez et épargnez ces instructions